

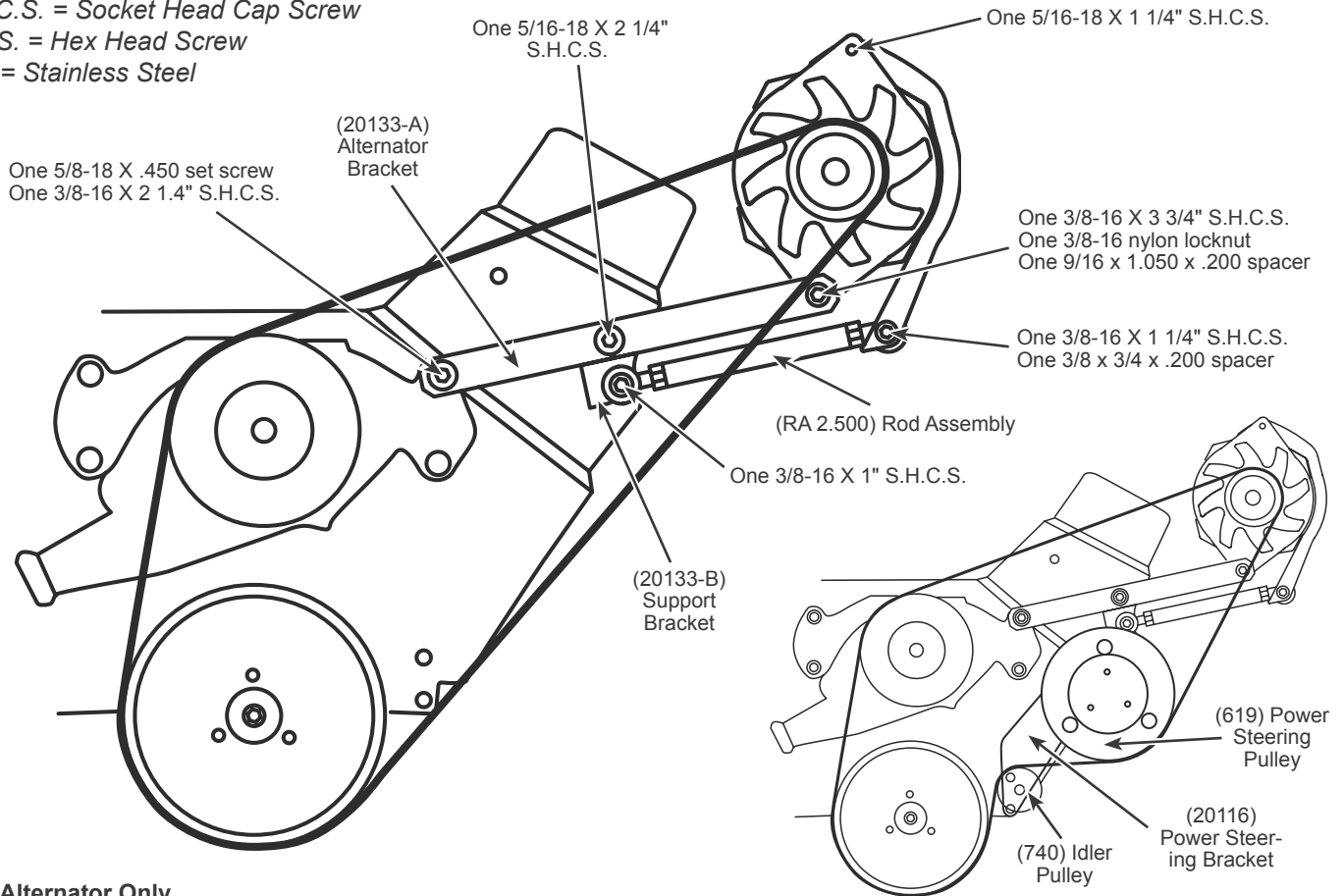

# #20133 Chevy Small Block Outward Mount Alternator Bracket

Revised 7-1-06

S.H.C.S. = Socket Head Cap Screw  
 H.H.S. = Hex Head Screw  
 S.S. = Stainless Steel



Alternator Only

Alternator & Remote P/S

## Parts List

- |                                                                                                                                                                                                                                                                                                                                                                                                                                                                                                                                                                                                                                                                                                                                                                           |                                                                                                                                                                                                                                                                                                                                                                                                                                                                                                                                                                                                                                                                                                                                                                                                        |
|---------------------------------------------------------------------------------------------------------------------------------------------------------------------------------------------------------------------------------------------------------------------------------------------------------------------------------------------------------------------------------------------------------------------------------------------------------------------------------------------------------------------------------------------------------------------------------------------------------------------------------------------------------------------------------------------------------------------------------------------------------------------------|--------------------------------------------------------------------------------------------------------------------------------------------------------------------------------------------------------------------------------------------------------------------------------------------------------------------------------------------------------------------------------------------------------------------------------------------------------------------------------------------------------------------------------------------------------------------------------------------------------------------------------------------------------------------------------------------------------------------------------------------------------------------------------------------------------|
| <ul style="list-style-type: none"> <li>1- (20133) Alt. Bracket Assembly</li> <li>1- (20133-A) Alt. Bracket</li> <li>1- (20133-B) Alt. Support Bracket</li> <li>2- (S106) 1/4-20 x 1 1/4 SHCS (mount A to B)</li> <li>1- (S452) 5/8-18 x .450 set screw (20133-Assm. to water-pump)</li> <li>1- (S260) 3/8-16 x 2 1/4" SHCS (20133-Assm. to waterpump)</li> <li>1- (S260) 3/8-16 x 2 1/4" SHCS (20133-Assm. to engine block)</li> <li>1- (S272) 3/8-16 x 3 3/4" SHCS (alternator to Alt. Bracket)</li> <li>1- (S622) 3/8-16 nylon locknut (alternator to Alt. Bracket)</li> <li>1- (BS3-1.050) 9/16 x 1.050 True Positioning Bushing</li> <li>1- (S148) 5/16-18 x 1 1/4" SHCS (Alt. Relocator Bracket to alternator)</li> <li>1- (20144) Alt. Relocator Bracket</li> </ul> | <ul style="list-style-type: none"> <li>1- (RA 3.500) Stainless Steel Rod Assembly</li> <li>1- (S248) 3/8-16 x 1" SHCS (SS Rod Assembly to Alt. Support Bracket)</li> <li>1- (S250) 3/8-16 x 1 1/4" SHCS (SS Rod Assembly to Alt. Relocator Bracket)</li> <li>1- (A3.200) 3/8 x 3/4 x .200 Spacer (between Rod end &amp; Alt Relocator Bracket)</li> </ul> <p><b>Power Steering with Kit</b></p> <ul style="list-style-type: none"> <li>1- (20116) Remote power Steering kit w/ 740 Idler</li> <li>Use pulley kit #6270</li> <li>Use power steering pulley #619</li> </ul> <p><b>Belt Sizes</b></p> <ul style="list-style-type: none"> <li>Alternator Only Kits uses 54 3/4" 6 rib belt.</li> <li>Remote Power Steering Kits uses 56" 6 rib belt when used with pulley kits #6270 and #6210.</li> </ul> |
|---------------------------------------------------------------------------------------------------------------------------------------------------------------------------------------------------------------------------------------------------------------------------------------------------------------------------------------------------------------------------------------------------------------------------------------------------------------------------------------------------------------------------------------------------------------------------------------------------------------------------------------------------------------------------------------------------------------------------------------------------------------------------|--------------------------------------------------------------------------------------------------------------------------------------------------------------------------------------------------------------------------------------------------------------------------------------------------------------------------------------------------------------------------------------------------------------------------------------------------------------------------------------------------------------------------------------------------------------------------------------------------------------------------------------------------------------------------------------------------------------------------------------------------------------------------------------------------------|

## Assembly Instructions

1. Bolt (20133) Alt. Bracket Assembly to engine block using one (S260) 3/8-16 x 2 1/4" socket head cap screw (do not tighten completely yet).
  2. Insert (S452) 5/8-18 x .450 set screw into (20133) Alt. Bracket Assembly, turning to rest against waterpump boss.
  3. Bolt (20133) Alt. Bracket Assembly to waterpump thru the (S452) 5/8-18 x .450 set screw using one (S260) 3/8-16 x 2 1/4" socket head cap screw.
  4. Tighten both 3/8-16 socket head cap screws.
  5. Bolt alternator to (20133) Alt. Bracket Assembly using one (S272) 3/8-16 x 3 3/4" socket head cap screw, one (S622) 3/8-16 nylon locknut & one (BS3-1.050) 9/16 x 1.050 True Positioning Bushing.
  6. Bolt (20144) Alt. Relocator Bracket to Alternator using one (S148) 5/16-18 x 1 1/4" socket head cap screw.
  7. Bolt (RA 3.500) Stainless Steel Rod Assembly to (20144) Alt. Relocator Bracket using one (S248) 3/8-16 x 1" socket head cap screw & one (A3.200) spacer.
  8. Bolt other end of (RA 3.500) Stainless Steel Rod Assembly to (20133-B) Alt. Support Bracket using one (S248) 3/8-16 x 1" socket head cap screw.
- (For kit #20462 install power steering, assemble per instructions)**
9. Install Belt.
  10. Adjust belt tension using (RA 3.500) Stainless Steel Rod Assembly.

**(Due to casting differences, flashing may need to be ground down around mounting points.)**

**\*(Note; (20133-B) Alt. Support Bracket can be painted to match color of engine block if desired)**