



#20151

Revised 1 -FGFI

# Power Steering Bracket Installation Chevy Big Block Long Water Pump

## Parts List

- 1-(20151-A) Power Steering Bracket
- 2-(TP3-1.980) Spacer
- 2-(S275) 3/8-16 x 4.25" SHCS
- 1-(S268) 3/8-16 x 3 1/4" SHCS
- 2-(S311) 3/8-16 x 3/4" HHCS
- 2-(S312) 3/8-16 x 1" HHCS
- 6-(S664) 3/8 x 1 x .080 spacer washers
- 1-(20176-A) Front Support Bracket

- 1-(20176-B) Rear Support Bracket
- H.C.S. = Socket Head Cap Screw  
 H.H.S. = Hex Head Screw  
 S.S. = Stainless Steel

Use 39.5" 5 rib serpentine belt for serpentine conversions

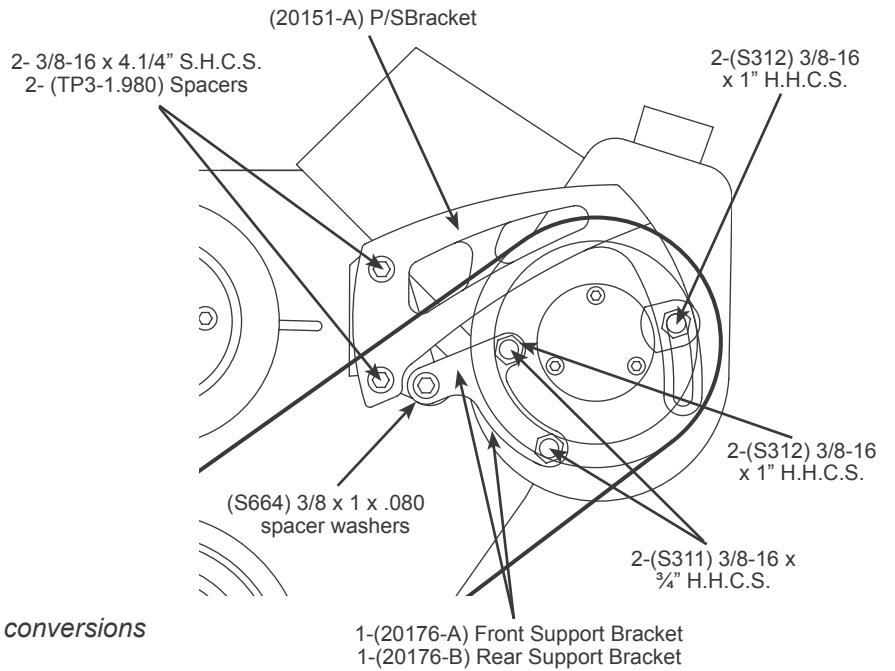

## Assembly Instructions (photos show Chevy small block kit but assembly is the same for big block)

1. Mount the (20151-A) Power Steering Bracket & water pump to engine block using two (S275) 3/8-16 x 4.1/4" SHCS & two (TP3-1.980) spacers (between (20151-A) Power Steering Bracket & water pump) (fig. 1).
2. If your power steering pump came equipped with a mounting stud at the rear of the pump, use an 11/16" wrench to remove the mounting stud from the pump unit (fig. 2).



Fig. 1



Fig. 2



Fig. 3

3. Mount the (20176-A) Front Support Bracket to the power steering pump using two (S311) 3/8-16 x 3/4" HHCS (fig. 3).
4. Mount the (20176-B) Rear Support Bracket to the power steering pump using one (S312) 3/8-16 x 1" HHCS & two (S664) 3/8 x 1" x .080 spacer washers. (fig. 4) Do not tighten at this time. (Note; due to variations of water pump boss castings, additional spacer washers may be needed.)

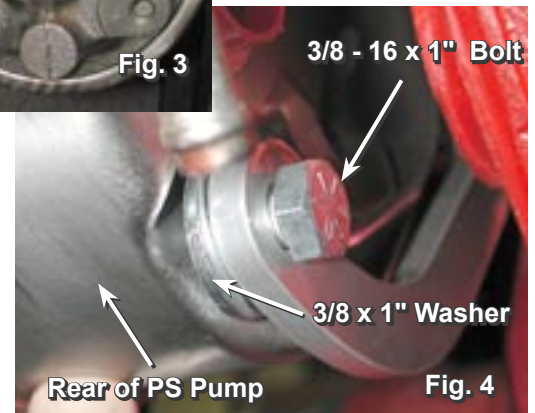

Fig. 4

5. Mount (20176-A & B) Support Brackets and P/S pump to water pump boss using one (S268) 3/8-16 x 3 1/4" SHCS. Leave loose enough for adjustment. Now tighten the (20176-B) Rear Support Bracket to the power steering pump.
6. Referring to (fig. 5), the power steering mounting face should meet the back of (20151-A) Power Steering Bracket. If not, use spacer washers in the appropriate places (fig. 4, fig. 6) to properly align pump.

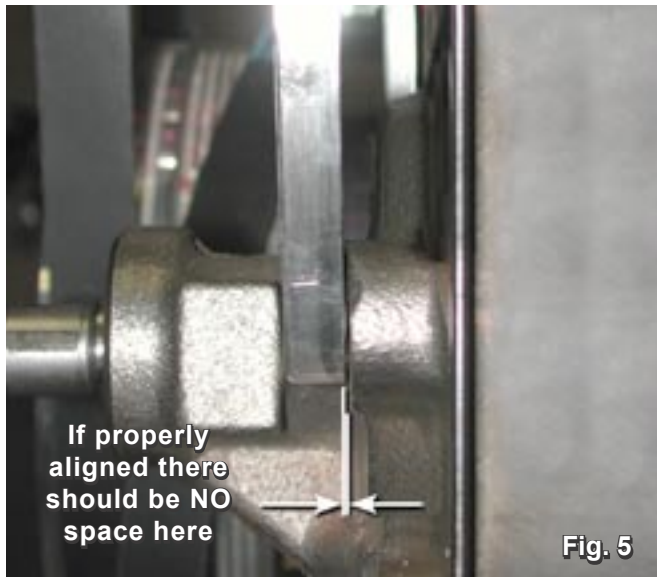

Fig. 5

**Important Note:** Due to variations in water pump boss castings particularly in aftermarket and polished pumps it may be necessary to add spacer washers between (20176-A) Front Support Bracket and the water pump boss. (fig. 6) [ !Á spacer washer between the (20176-B) Rear Sup] [ ic Óæ & ^ ã ä Á [ , ^! Á c ^ ^ ã \* Á { ] É ç È D U @ Á Á & ! ! ^ & ç ã } { ^ } É

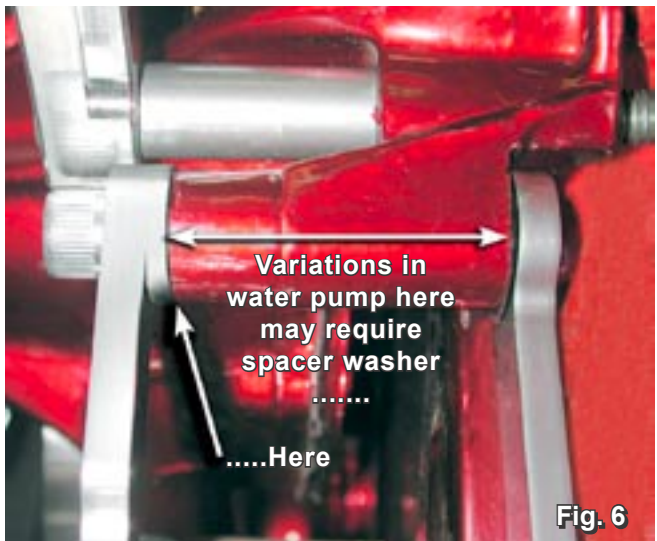

Fig. 6

7. Mount (20151-A) Power Steering Bracket to power steering pump using one (S312) 3/8-16 x 1" HHCS & one (S664) washer. (fig. 7) Leave loose for adjustment.

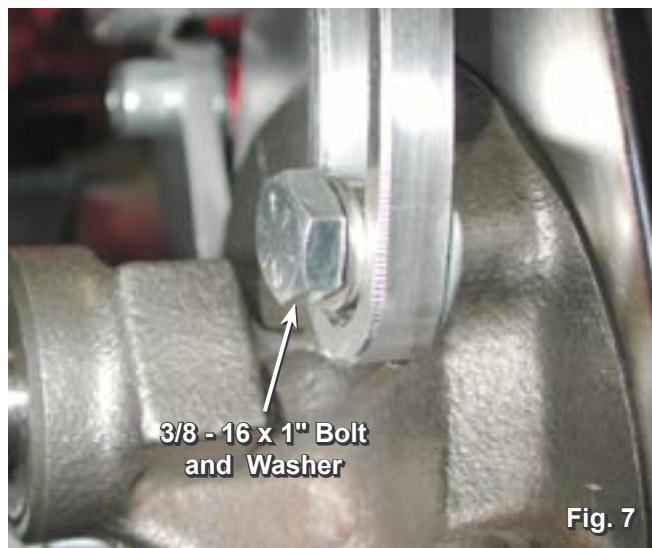

Fig. 7

8. Mount power steering pulley to power steering pump shaft. Check power steering pulley to crank pulley alignment. Install belt (Use 39.5" 5 rib serpentine belt for serpentine conversions) and adjust belt tension by pulling up on the power steering pump. Belt tension is correct when there is no more than 1/4" play in the belt at midpoint between the power steering pulley & the crank pulley. Lock the belt tension by tightening the adjustment bolt with a 9/16" opened end wrench (fig. 8).

Tighten (S268) 3/8-16 x 3 1/4" SHCS (step 5) & (S311) 3/8-16 x 3/4" SHCS (step 7).

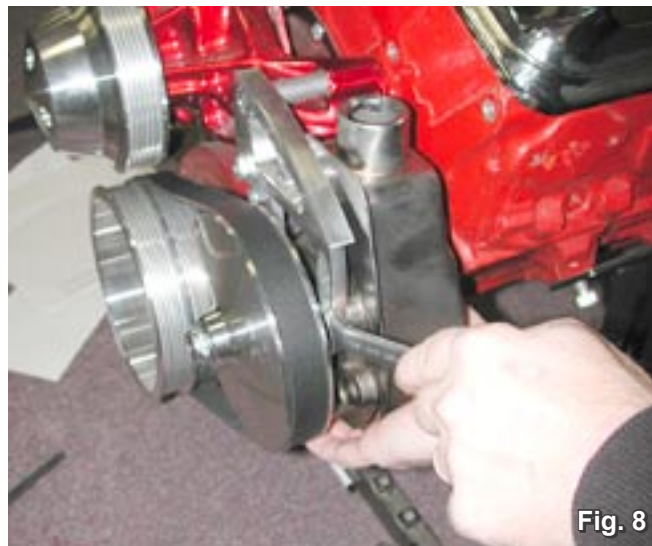

Fig. 8