

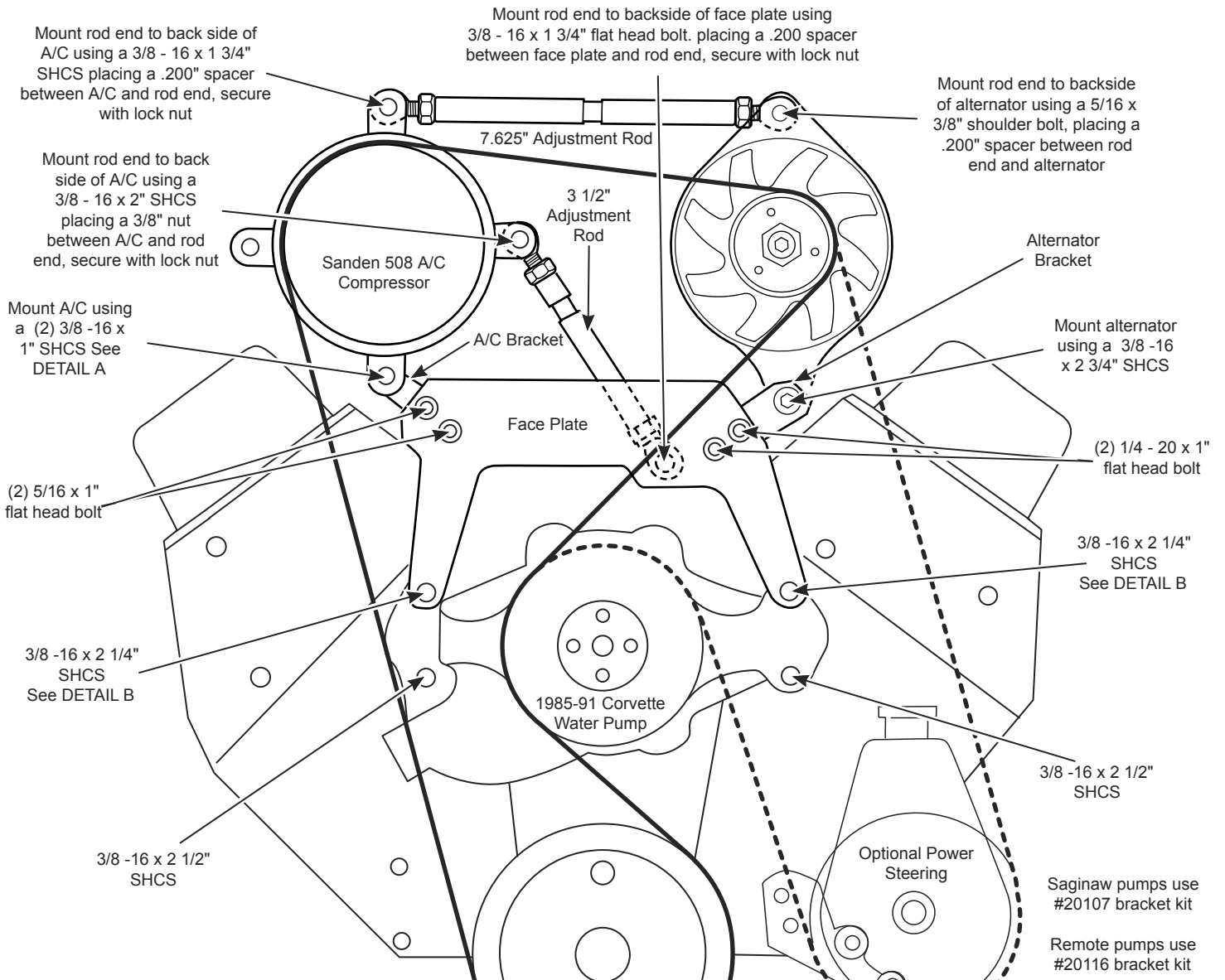

# #20700 Chevy Small Block High Mount Alternator & A/C Bracket Kit

Revision 6-4-07



### DETAIL A

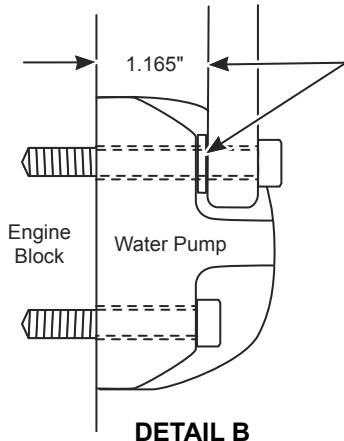
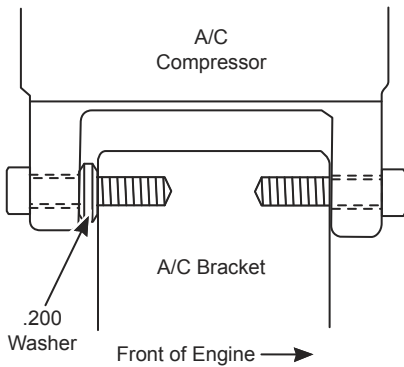

Use washers between face plate and water pump flange mount to achieve a 1.165" space between face plate and engine block

### DETAIL C

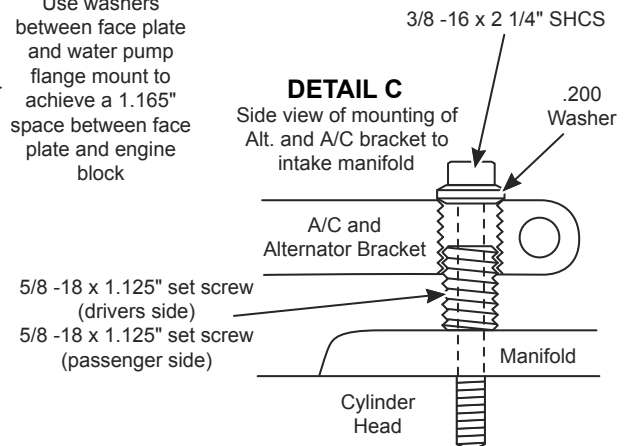

### Belt Sizes:

- 20710 use Dayco #5060650
- 20711, 20712 use Dayco #5060895
- 20713 use Dayco #5060850

MARCH PERFORMANCE, INC. • 16160 PERFORMANCE WAY • NAPLES, FLORIDA 34110

Technical Support 888-729-9070

Revised 3/1/2017

**LIMITED WARRANTY**

March Performance warrants to the original retail purchaser that for a period of ninety (90) days from the date of purchase, March Performance will repair or replace, at their option, any Product, which is found to be defective in material or workmanship.

**Exclusions from Warranty Coverage**

March Performance does not warrant any Product that is damaged from abuse, misuse or misapplication or not used for its intended purposes.

This Limited Warranty does not cover or apply to any damage or loss sustained to the engine or any other parts which may have been caused by the defective Product and does not cover or apply to any personal injury, labor charges or any other incidental costs for damages caused by the defective Product. THIS IS THE ONLY EXPRESS WARRANTY GIVEN WITH RESPECT TO YOUR PRODUCT. ALL OTHER EXPRESS WARRANTIES, GUARANTEES, OR STATEMENTS REGARDING THE PRODUCT, WHETHER WRITTEN OR VERBAL, ARE HEREBY DEEMED NULL AND VOID AND OF NO EFFECT.

Normal wear and tear and damage to the Product not caused by March Performance are also excluded from this Warranty.

**DISCLAIMER OF OTHER WARRANTIES**

EXCEPT TO THE EXTENT PROHIBITED BY APPLICABLE LAW, ANY IMPLIED WARRANTY WHETHER OF MERCHANTABILITY, FITNESS FOR A PARTICULAR PURPOSE, OR WARRANTY, SOME STATES DO NOT ALLOW LIMITATIONS ON HOW LONG AN IMPLIED WARRANTY WILL LAST SO THAT THE PRECEDING LIMITATION MAY NOT APPLY TO YOU.

**Limitation on Remedies**

REPAIR OR REPLACEMENT AS PROVIDED IN THIS WARRANTY IS YOUR EXCLUSIVE REMEDY. MARCH PERFORMANCE SHALL NOT BE LIABLE FOR ANY INCIDENTAL OR CONSEQUENTIAL DAMAGE FOR BREACH OF ANY EXPRESS OR IMPLIED WARRANTY ON THE PRODUCT. SOME STATES DO NOT ALLOW THE EXCLUSION OR LIMITATION OF INCIDENTAL OF CONSEQUENTIAL DAMAGES SO THE PROCEEDING LIMITATION OR EXCLUSIONS MAY NOT APPLY TO YOU. YOU HAVE NO RECOURSE OR REMEDY FOR DAMAGE OR DEFECT CAUSED BY MISUSE, ABUSE OR NEGLIGENCE.

THIS WARRANTY GIVES YOU SPECIFIC RIGHTS AND YOU MAY ALSO HAVE OTHER RIGHTS, WHICH MAY VARY FROM STATE TO STATE.

**Your Responsibilities:**

1. Use and install the Product only for its intended purpose.
2. To avail yourself of this Limited Warranty, return the Product with a copy of the paid receipt, postage paid to:  
**MARCH PERFORMANCE**  
**16160 PERFORMANCE WAY**  
**NAPLES, FL 34110**
3. When returning the Product, you must follow the directions set forth on the Warranty/Return Form on the reverse side of this Limited Warranty. If you no longer have the Warranty/Return Form, one may be obtained by contacting March Performance during normal business hours at: (888) 729-9070.
4. Shipping and/or transportation costs returning the Product to March Performance and any damage caused during shipping are your responsibility. March Performance will pay for shipping and/or transportation costs incurred in returning the Product to you.

**MARCH PERFORMANCE WARRANTY/RETURNS FORM**

revised 03/01/2017

**No product mounted is considered for credit** unless it is a manufacturer defect.

All products returned for any reason must reference an authorization number (RGA). The RGA number is obtained by calling place of purchase during normal business hours. **Any product returned without the RGA# written on the return package next to the return shipping label will be refused.**

All returns must ship via UPS and be properly packaged in the original carton. Return freight charges are the responsibility of the customer unless the product was shipped in error.

March product returned after (1) year from date of purchase will not be accepted unless it is found to be a manufacturer defect. **The customer must include a written statement describing the alleged product defect.** The complete Limited Warranty is set forth on the reverse side.

100% credit issued on manufacturer defects

20% return fee on all reshelvable product

30% return fee on all repairable product

**NO CREDIT WILL BE ISSUED ON RETURNED PRODUCT BEYOND REPAIR**

March Performance thoroughly inspects all returns. It is the sole discretion of March Performance in determining the condition of all returned merchandise.

To receive replacements at no charge the original product must first be received and inspected by March Performance for determination. Immediate replacements may be purchased and later credited upon inspection determination.

Please Complete the Information below, detach and include with returned product.

RGA# \_\_\_\_\_ CT# \_\_\_\_\_ Issued by: \_\_\_\_\_ Date \_\_\_\_\_

Purchaser's Name \_\_\_\_\_ Phone \_\_\_\_\_

Address \_\_\_\_\_

Purchased Directly Through \_\_\_\_\_ Invoice# \_\_\_\_\_

Reason \_\_\_\_\_

**\*\* MOUNTED PRODUCTS ARE NONREFUNDABLE \*\***